

103-105 TESTE PER COLTELLI PROFILATI

103-105 CUTTER HEADS WITH PROFILED KNIVES

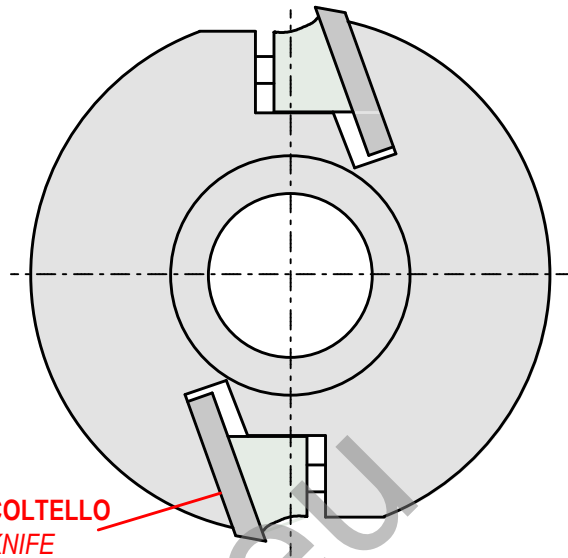

103

MEC

Codice	D. mm.	B mm.	d. mm.	Z	
--------	-----------	----------	-----------	---	--

103 10	100	40	30	2	n max 8000
103 12	120	40	30-35	2	n max 7000

FORI A RICHIESTA-BORES ON REQUEST-mm 31.75-40-50

COLTELLI NON COMPRESI CON LA TESTA
KNIVES NOT INCLUDED WITH THE HEAD

105

MEC

Codice	D. mm.	B mm.	d. mm.	Z	
--------	-----------	----------	-----------	---	--

105 10	100	50	30	2	n max 8000
105 12	120	50	30-35	2	n max 7000

FORI A RICHIESTA-BORES ON REQUEST-mm 31.75-40-50

COLTELLI NON COMPRESI CON LA TESTA
KNIVES NOT INCLUDED WITH THE HEAD

RICAMBI-SPARE PARTS

Codice nr.	Dimensioni	
000/138B	38 mm	CUNEO-WEDGE-ART.103
138-48	48 mm	CUNEO-WEDGE-ART.105
000/008B	M10x20	GRANI-SCREWS-D.100
000/008C	M10x25	GRANI-SCREWS-D.120
000/034	5 mm	CHIAVE ESAG.-WRENCH

103

TESTE PORTACOLTELLI PER AVANZAMENTO MECCANICO.
SECONDO NORMATIVE EUROPEE EN 847-1.
CORPO IN ACCIAIO PER COLTELLI 40 x 4 mm.

USARE COLTELLI DAL Nr.1 AL Nr.177

103

CUTTER HEAD FOR MECHANICAL FEED ACCORDING TO
THE EUROPEAN SAFETY RULE 847-1. STEEL BODY FOR
KNIVES 40 x 4 mm.

TO USE KNIVES FROM Nr.1 TO Nr.177

105

TESTE PORTACOLTELLI PER AVANZAMENTO MECCANICO.
SECONDO LE NORMATIVE EUROPEE EN 847-1.
CORPO IN ACCIAIO PER COLTELLI 50 x 5.5.

USARE COLTELLI DAL Nr.F200/5 AL Nr.F233/5

105

CUTTER HEAD FOR MECHANICAL FEED ACCORDING TO
THE EUROPEAN SAFETY RULE 847-1. STEEL BODY FOR
KNIVES 50 x 5.5 mm.

TO USE KNIVES FROM Nr.F200/5 TO Nr.233/5